



PARTS LIST

 **M-1001.PJ** 







I. COVER COMPONENT (カバー機構)

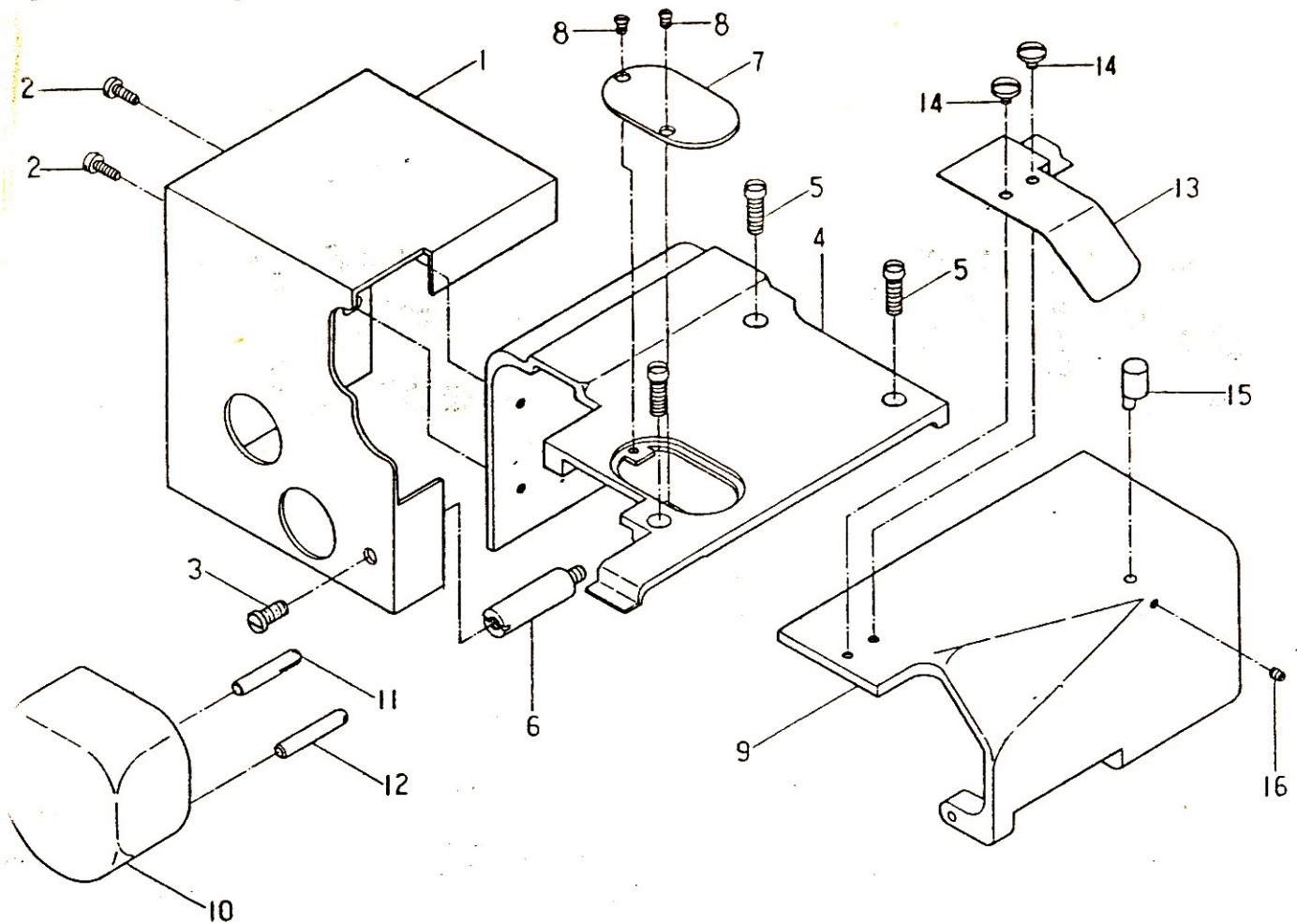

MO

Mega
10-19
Osaka

Tel: (0)

MAIN

180.1

Tel: (0)

TOKY

16-7.

Tel: (0)

OKAY

Biregg

Tel: (0)

AKITA

14-8.

Tel: (0)

KANS

51 R

Tel: 2

MORI

C-2 2

Tel: 5

MORI

50 Ki

Tel: 2

MORI

Sedar

Tel: 3

NO	Part NO	Part name	品名	Q'ty
1	21-742	Gear cover	ギヤカバー	1
2	84-566	Screw	ネジ	2
3	84-763	Screw	ネジ	1
4	21-741	Upper base cover	上ベースカバー	1
5	84-764	Screw	ネジ	3
6	84-841	Screw	カバー取付土台ネジ	1
7	21-130	Feed adjusting cover	送り調節カバー	1
8	84-463	Screw	ネジ	2
9	21-184	Puier table	定規台	1
10	21-144	End cover	エンドカバー	1
11	71-109	Screw	ネジ	1
12	71-108	Screw	ネジ	1
13	21-143	Puler table auxiliary cover	化粧カバー	1
14	84-370	Screw	ネジ	2
15	71-116	Screw	定規台止ネジ	1
16	84-314	Screw	ネジ	1

2. GUIDE COMPONENTS FOR PRESSER FOOT

(押エガイド機構)

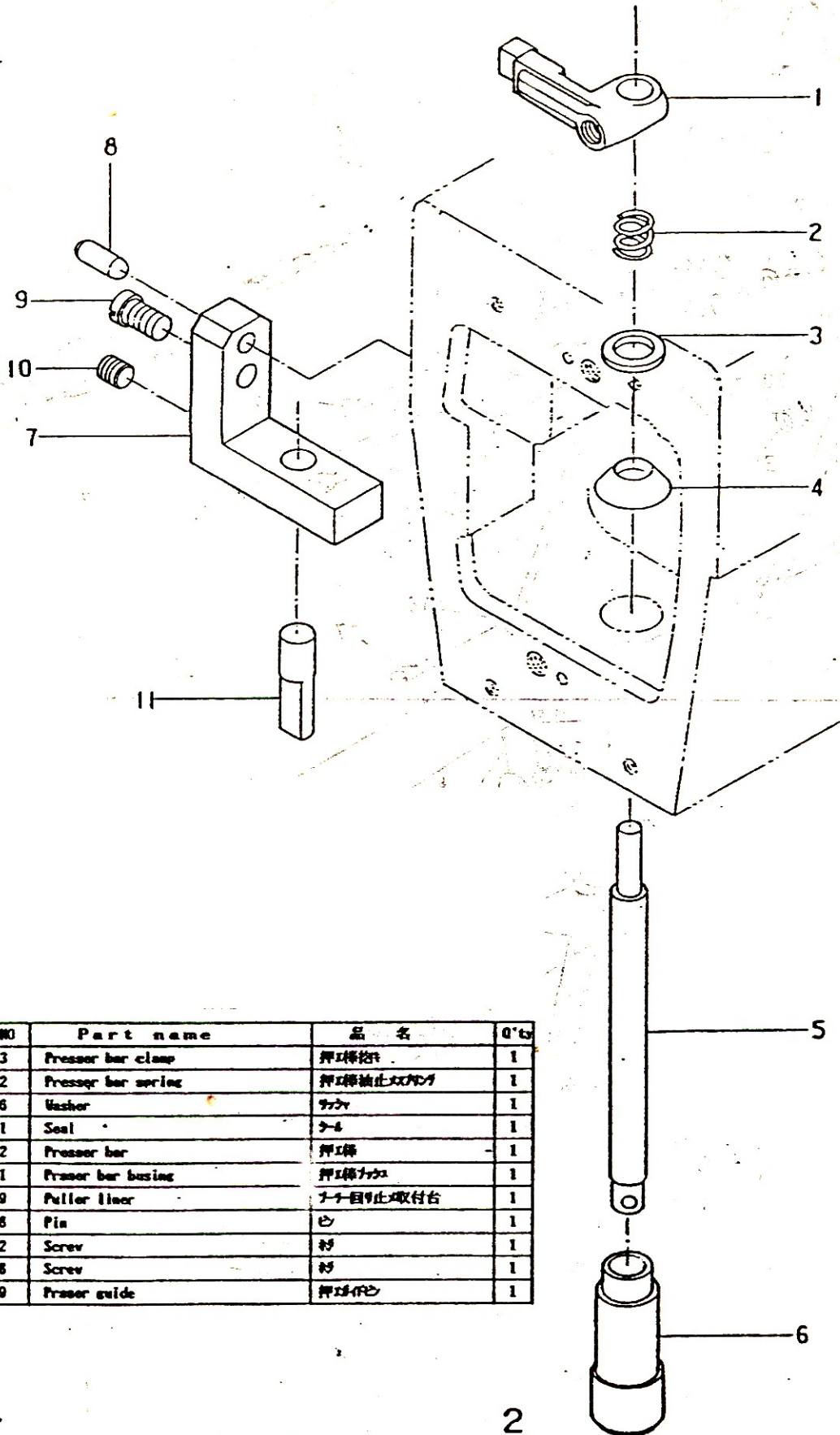

NO	Part NO	Part name	品名	Q'ty
1	77-803	Presser bar clamp	押エ棒抱片	1
2	79-042	Presser bar spring	押エ棒軸止スプリング	1
3	75-436	Washer	ワッシャー	1
4	23-311	Seal	シール	1
5	71-042	Presser bar	押エ棒	1
6	81-041	Presser bar bushing	押エ棒ブッシング	1
7	02-139	Puller liner	プーリ回止取付台	1
8	71-228	Pin	ピン	1
9	84-762	Screw	ネジ	1
10	84-718	Screw	ネジ	1
11	01-039	Presser guide	押エガイド	1

3. THREAD EYELET COMPONENTS (糸調子機構)

MI001PJ UTC専用

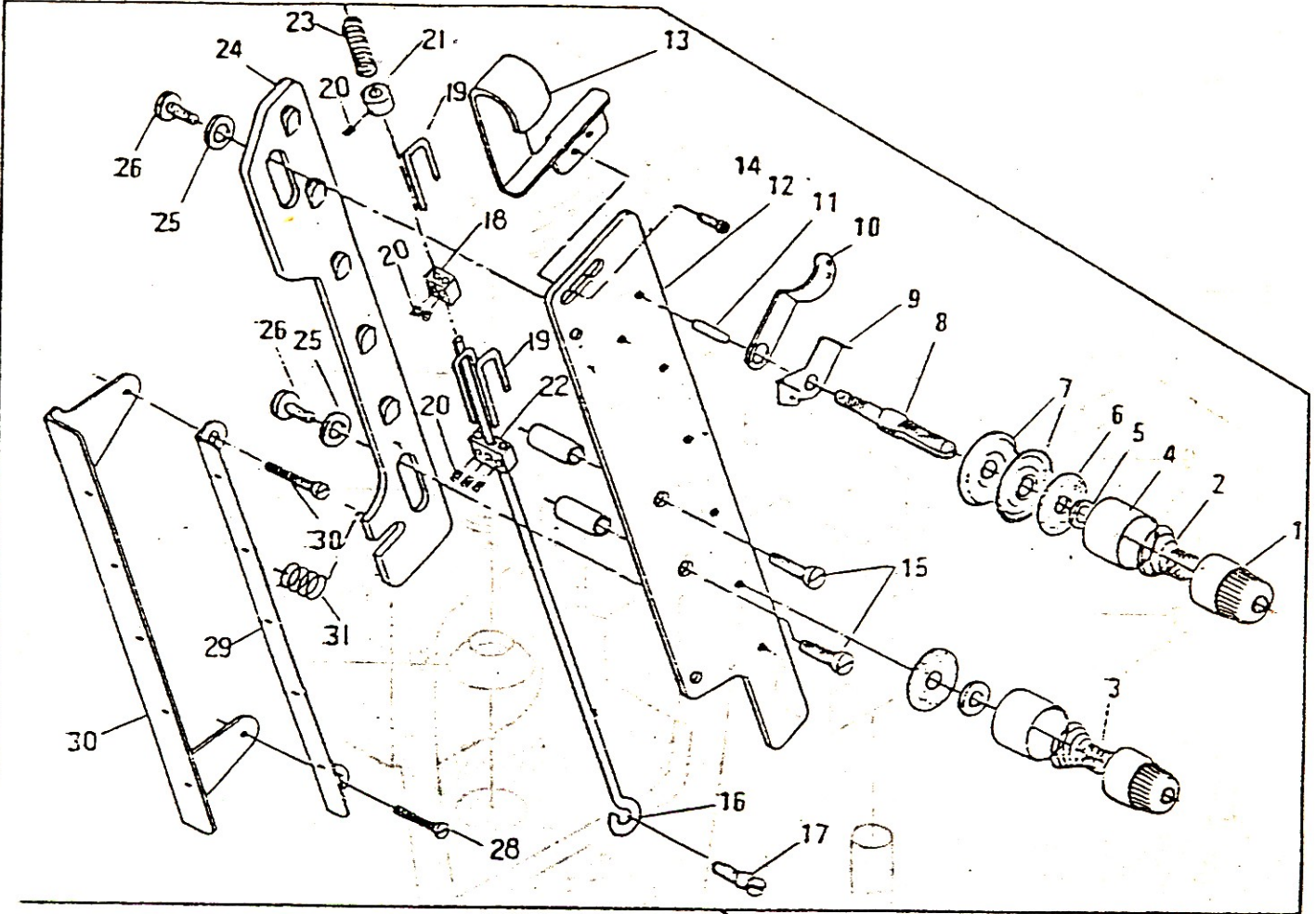

MI001PJ UTCナシ専用

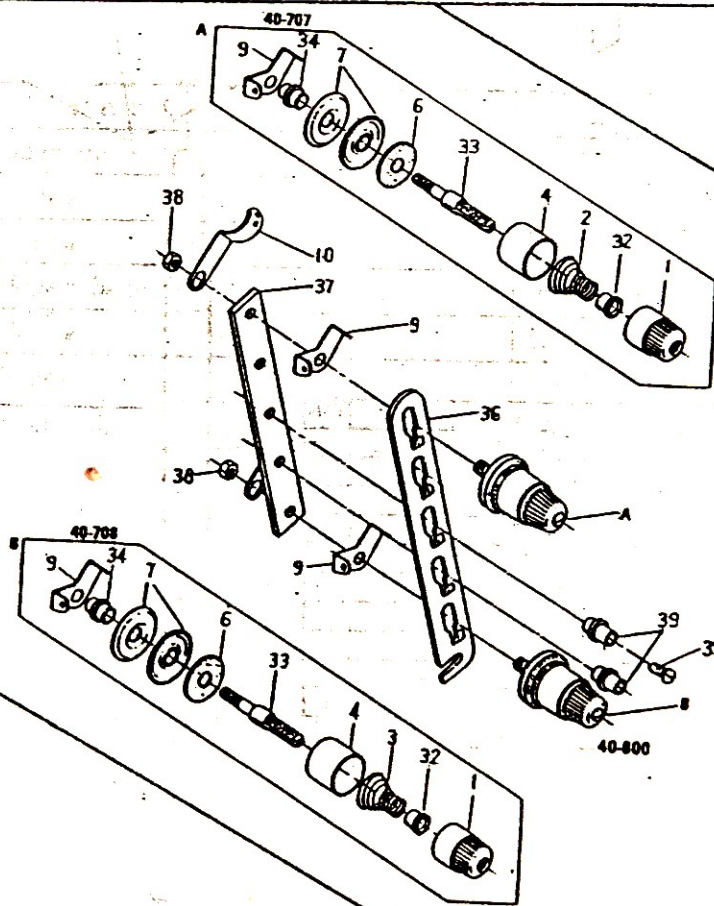

NO	Part NO	Part name	品名	UTC	
				専用	汎用
1	41-101	Adjusting nut	小ケース	2	2
2	41-701	Spring (strong)	調子棒(強)	1	1
3	41-702	Spring (weak)	調子棒(弱)	1	1
4	41-107	Disc cover	大ケース	2	2
5	33-802	Tension disc washer	ファン座金	2	
6	23-324	Felt	フェルト	2	2
7	41-111	Disc	ファン皿	4	4
8	41-175	Tension post	糸調子棒	2	
9	41-115	Thread eyelet	糸道	2	2
10	41-117	Thread eyelet	糸道	2	2
11	06-944	Thread release pin	ピン	2	
12	41-729	Tension post holder	ファン元台	1	
13	06-948	Thread release post guide	糸緩め案内棒	1	
14	84-361	Screw	ネジ	2	
15	84-765	Screw	ネジ	2	
16	41-726	Thread release post	糸緩め棒	1	
17	84-792	Screw	ネジ	1	
18	06-067	Hook holder	糸緩めスライド	1	
19	06-071	Hook	糸緩め用フック	3	
20	84-314	Screw	ネジ	6	
21	75-941	Thread release cushion cover	糸緩めクッションカバー	1	
22	06-017	Hook B	糸緩めスライド B	1	
23	79-914	Thread release cushion spring		1	
24	41-730	Tension post support	ファン調節板	1	
25	75-942	Tension post collar	糸道カラー	2	
26	84-559	Tension post slide screw	糸道ネジ	2	
27	75-943	Tension post collar	ファン調節カラー	2	
28	84-374	Screw	ネジ	2	
29	41-728	Thread release guide thread eyelet(right)	糸緩め案内糸道(右)	1	
30	41-727	Thread release guide thread eyelet(left)	糸緩め案内糸道(左)	1	
31	79-164	Spring	棒	1	
32	41-105	Adjusting ratchet	ファン皿ラチェット		2
33	41-172	Tension post	調子棒中		2
34	41-131	Collar	調子棒カラーA		2
35	84-764	Screw	押し揚げ連結板止めネジ		2
36	41-236	Tension post support	ファン皿調節板		1
37	41-237	Tension post holder	ファン元板		1
38	86-411	Nut	連結棒用ナット		2
39	41-132	Tension post collar	調子棒カラーB		2

4. PRESSER FOOT REAR PULLER COMPONENTS

(押エ.後プラー台機構)

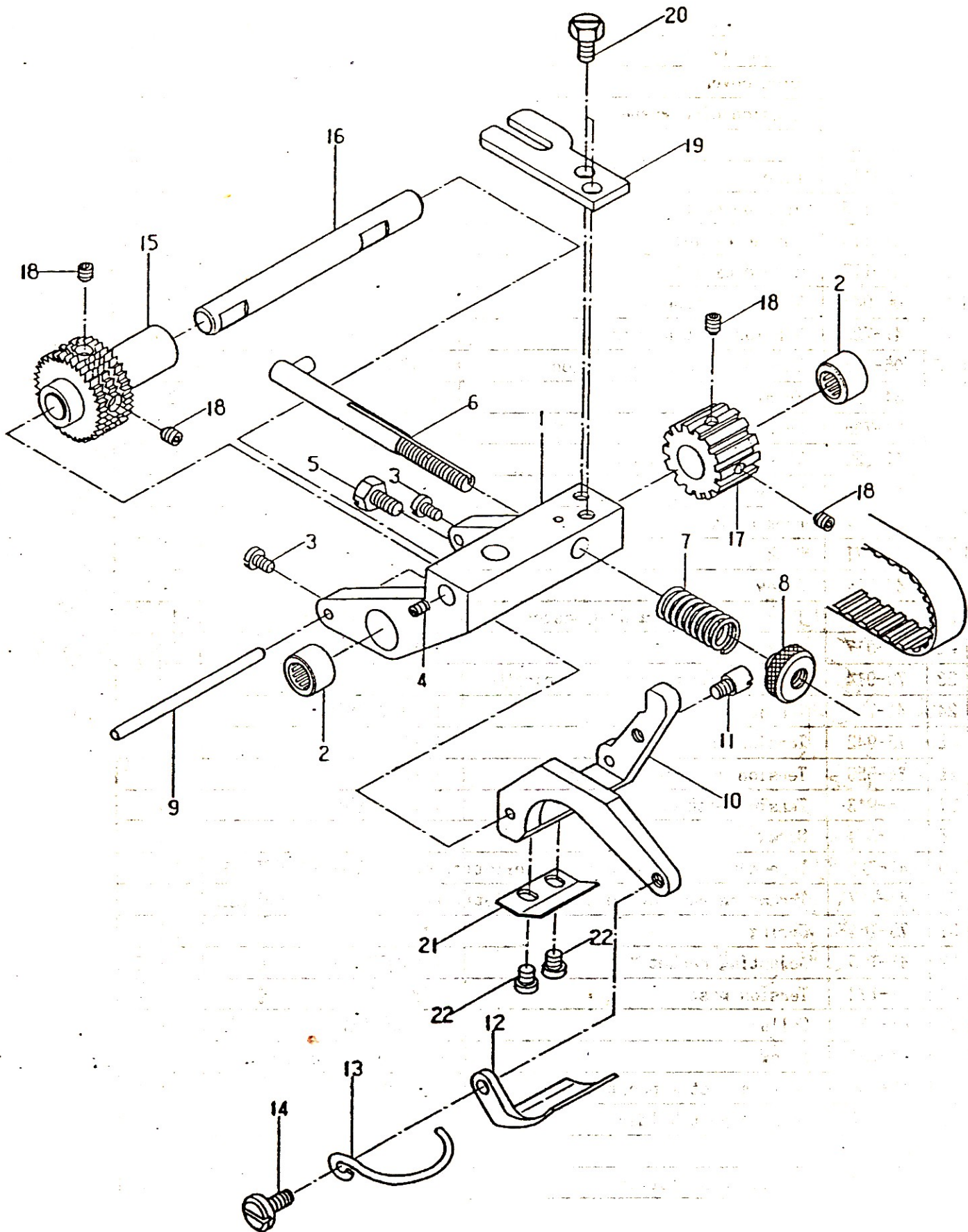

5. REAR PULLER GEAR HOUSING COMPONENTS

(後プラーギヤハウジング機構)

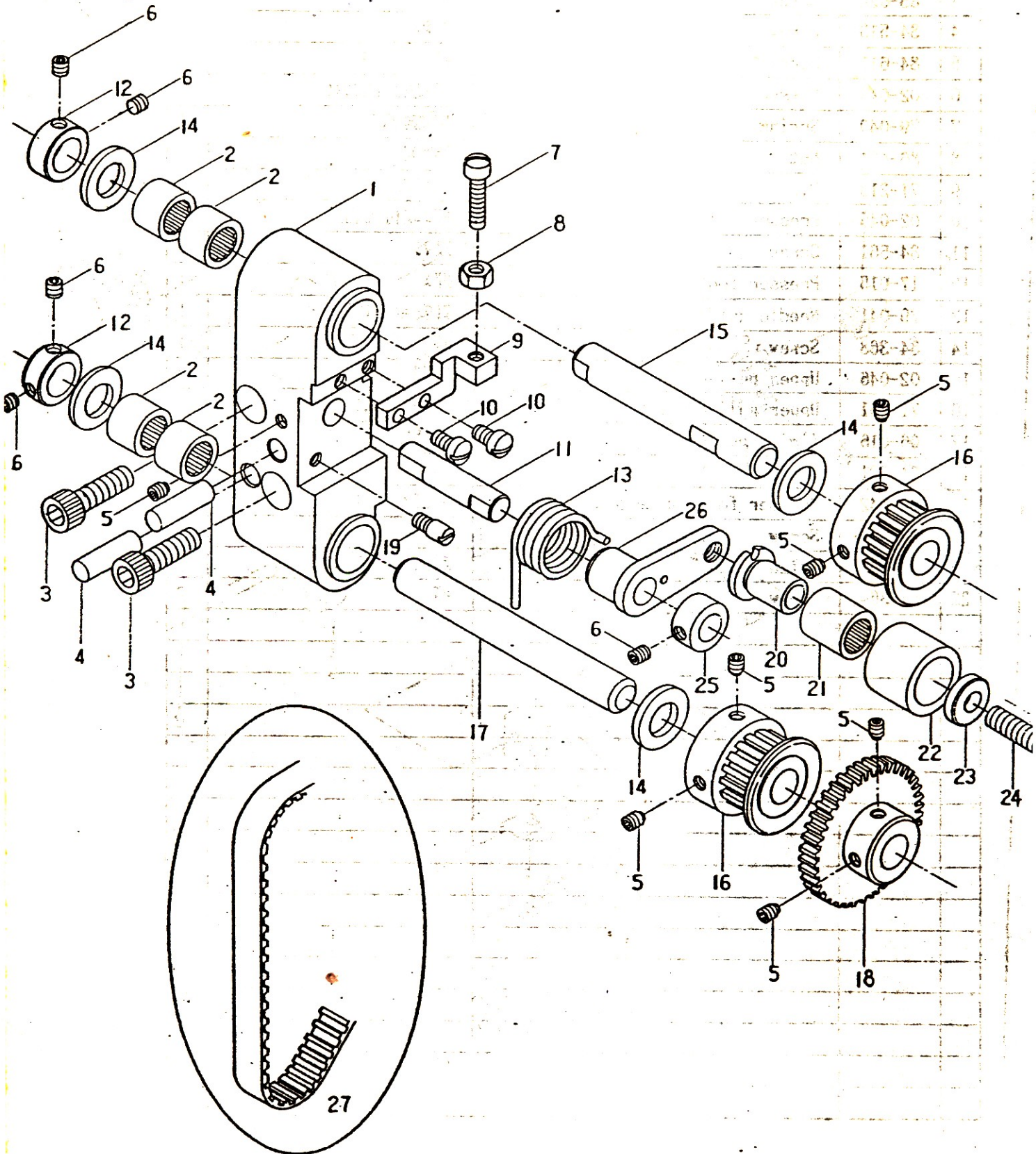

6. REAR PULLER DRIVE COMPONENTS (後プーラードライブ機構)

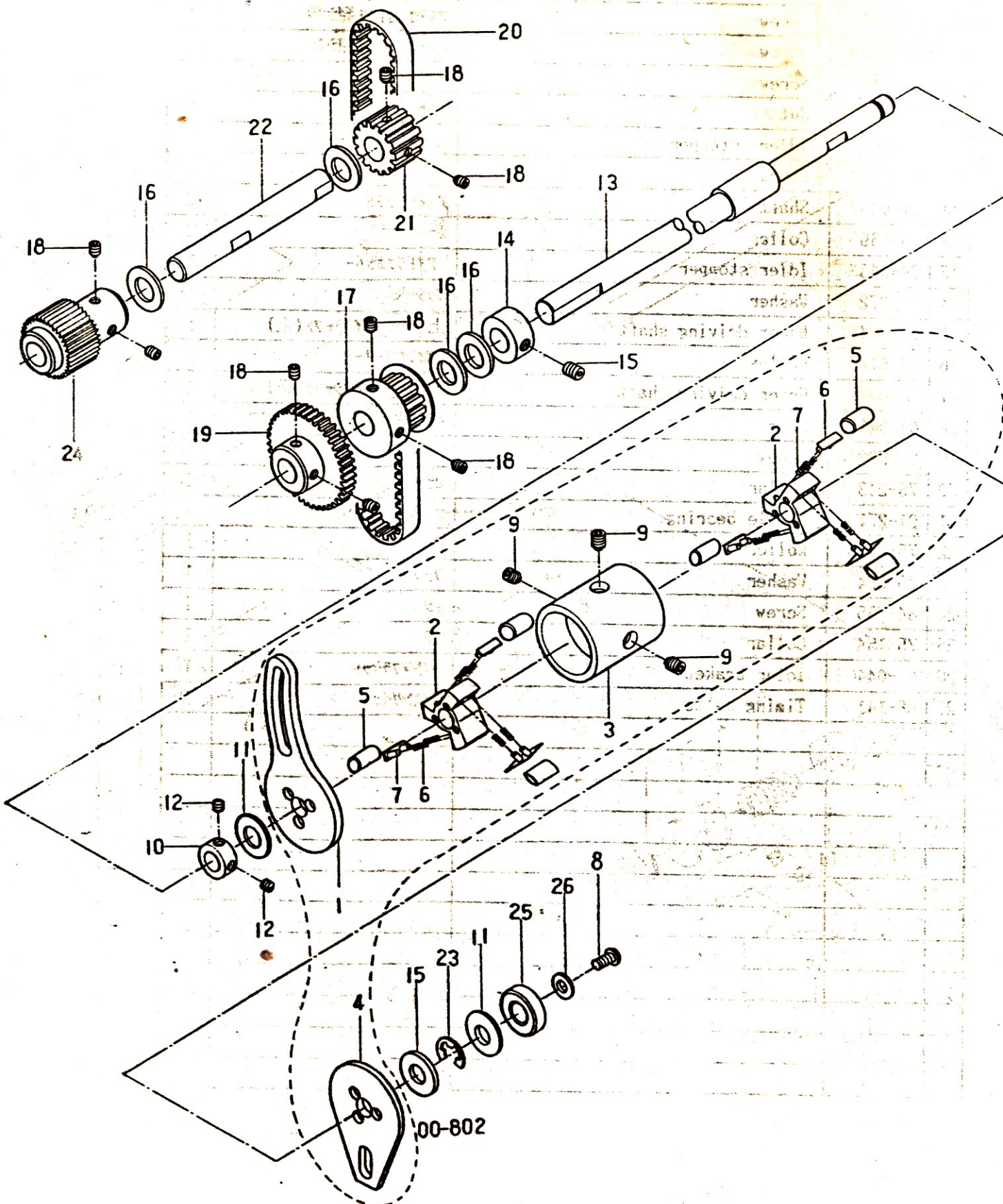

7. GUIDE (2) (PJホルダ-機構)

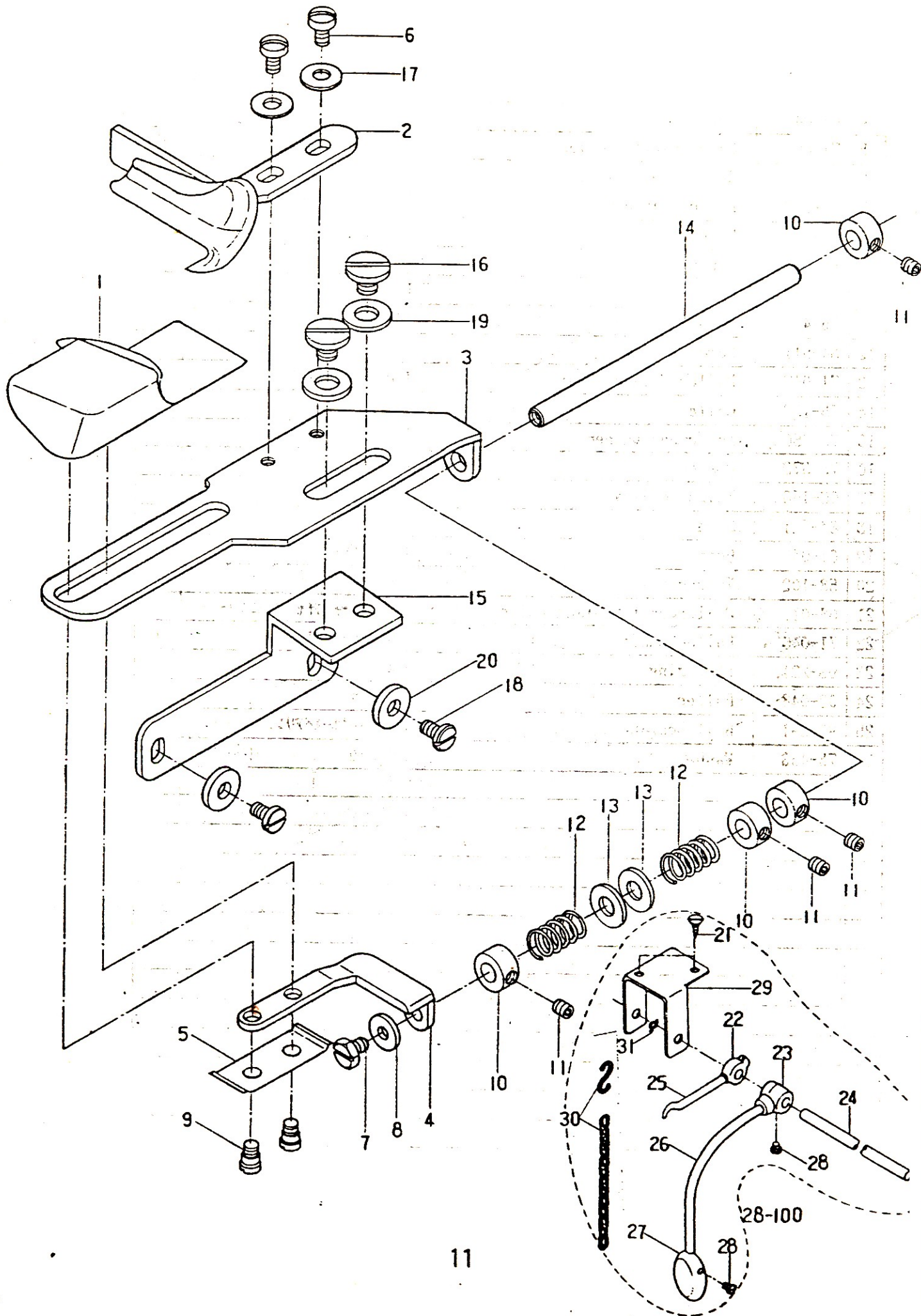

8. GUIDE (I) (ホルダー連動装置)

MI001PJ UTCナシ専用

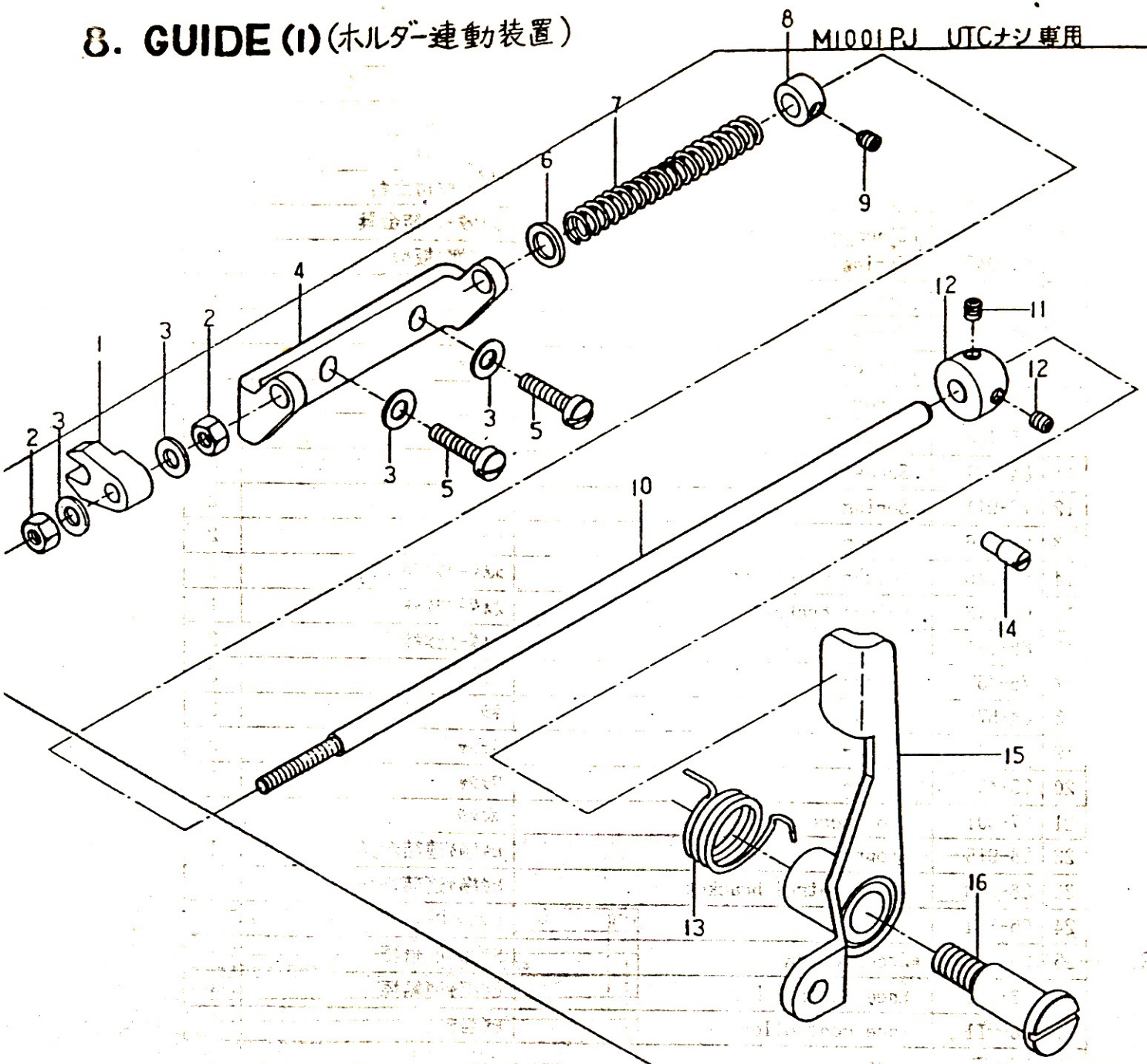

MI001PJ UTC専用

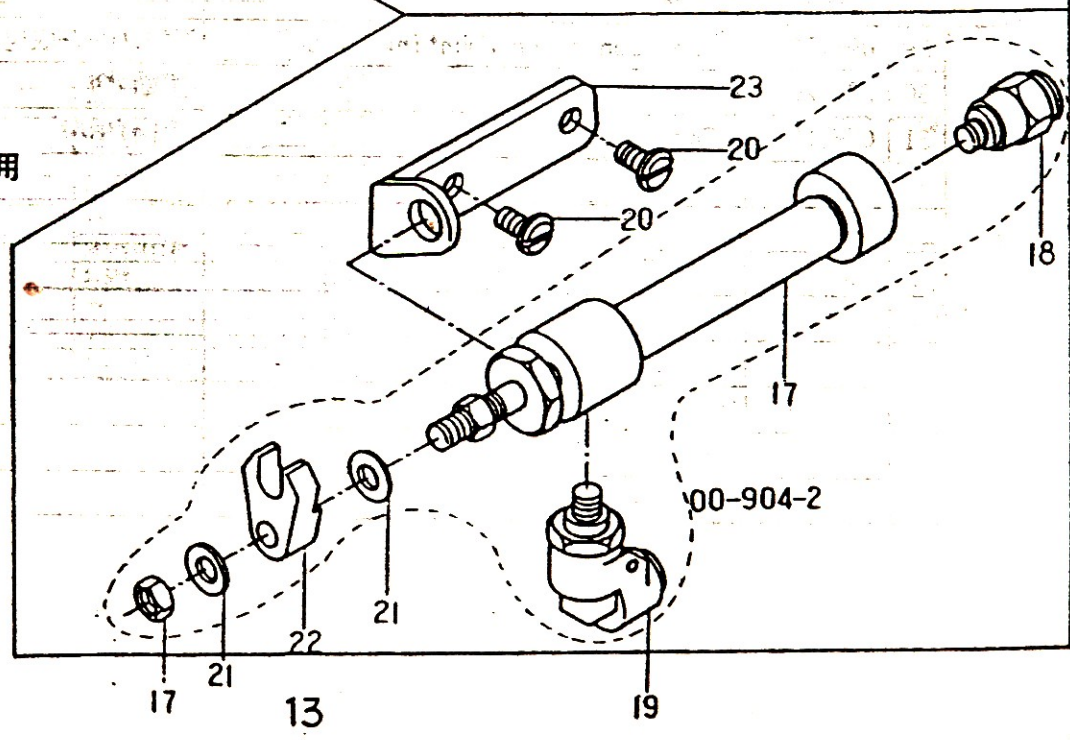

9. GAUGE PARTS (ゲージ関係)

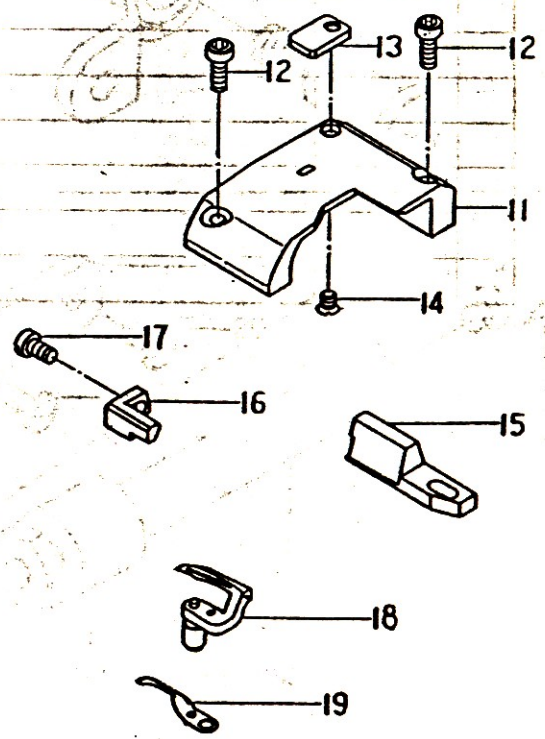
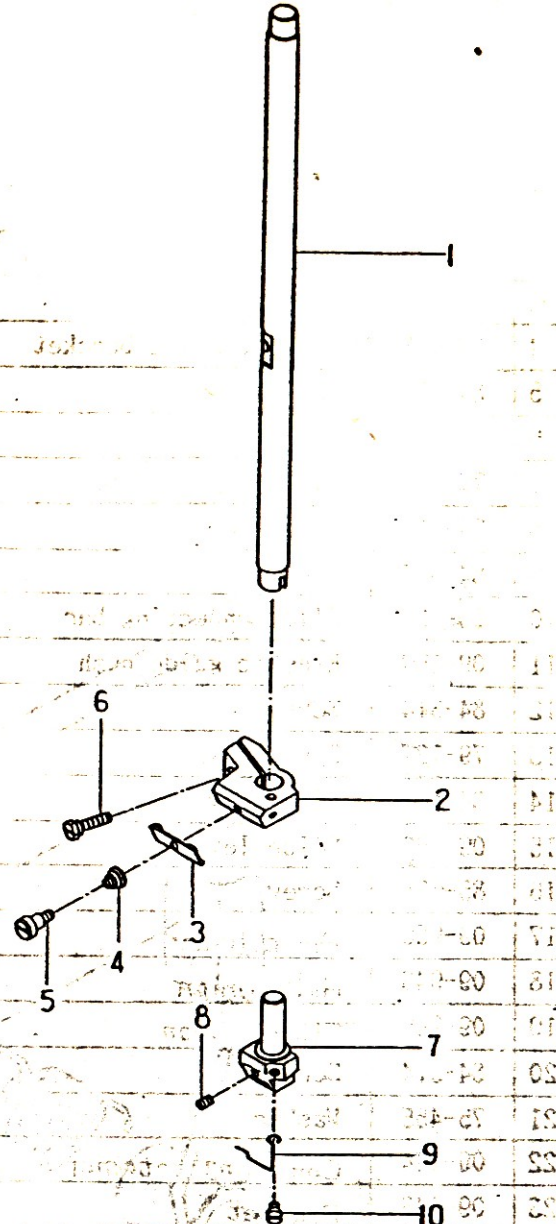

NO	Part NO	Part name	品名	Qty
1	11-804	Needle bar	針棒	1
2	41-041	Tension nipper bracket	針棒クワ糸道台B	1
3	45-142	Tension nipper	糸道B	1
4	41-722	Spring	針	1
5	84-171	Screw	針	1
6	84-413	Screw	針	1
7	12-015	Needle clamp	針株	1
8	84-314	Screw	針	1
9	45-234	Needle thread guide	針線糸行D	1
10	84-263	Screw	針	1
11	14-015	Needle plate	針板	1
12	87-113	Screw	針	2
13	26-040	Needle plate guide	針板ガイド	1
14	84-465	Screw	針	1
15	18-741	Feed dog	針受け取付台	1
16	18-110	Needle guard	針受け	1
17	84-564	Screw	針	1
18	19-015	Looper	ル-A	1
19	18-101	Looper needle guard	補助ル-A	1